

Instant Robot Programming system

Exner

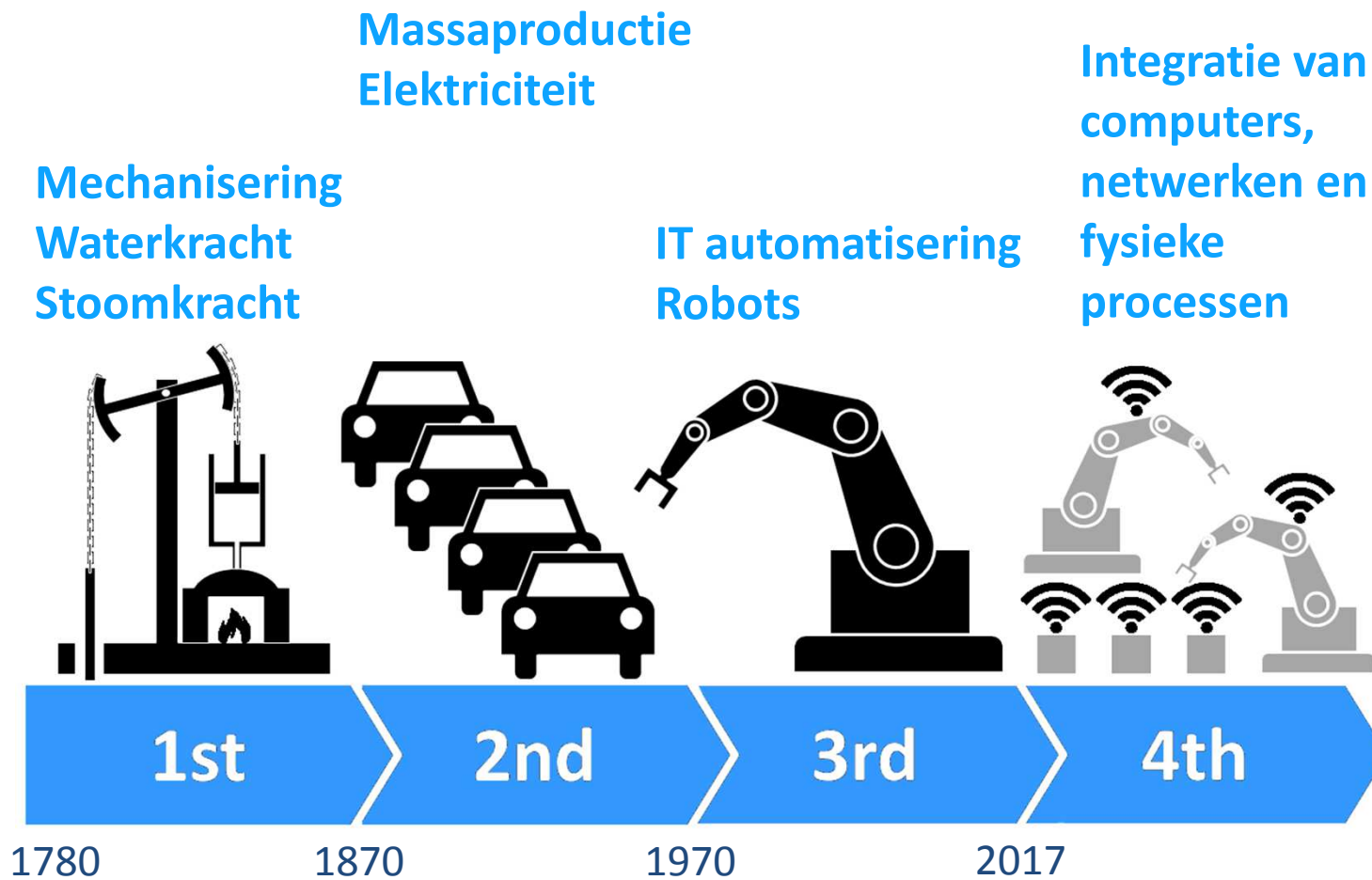

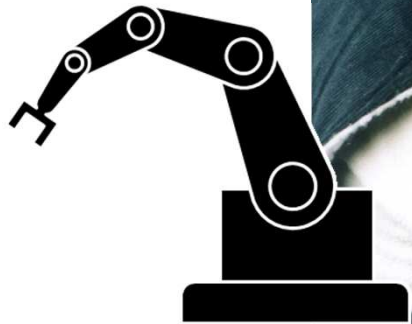



3rd

Online Robot programmeren

Exner

Online programmering: Erg tijdrovend maar je ziet wel wat je doet



3rd

Online Robot programmeren

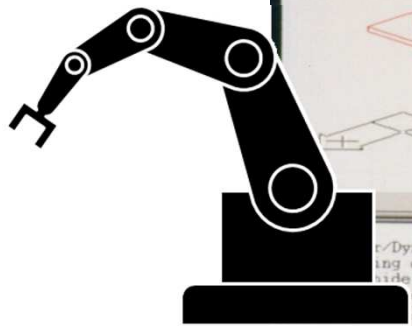

3rd

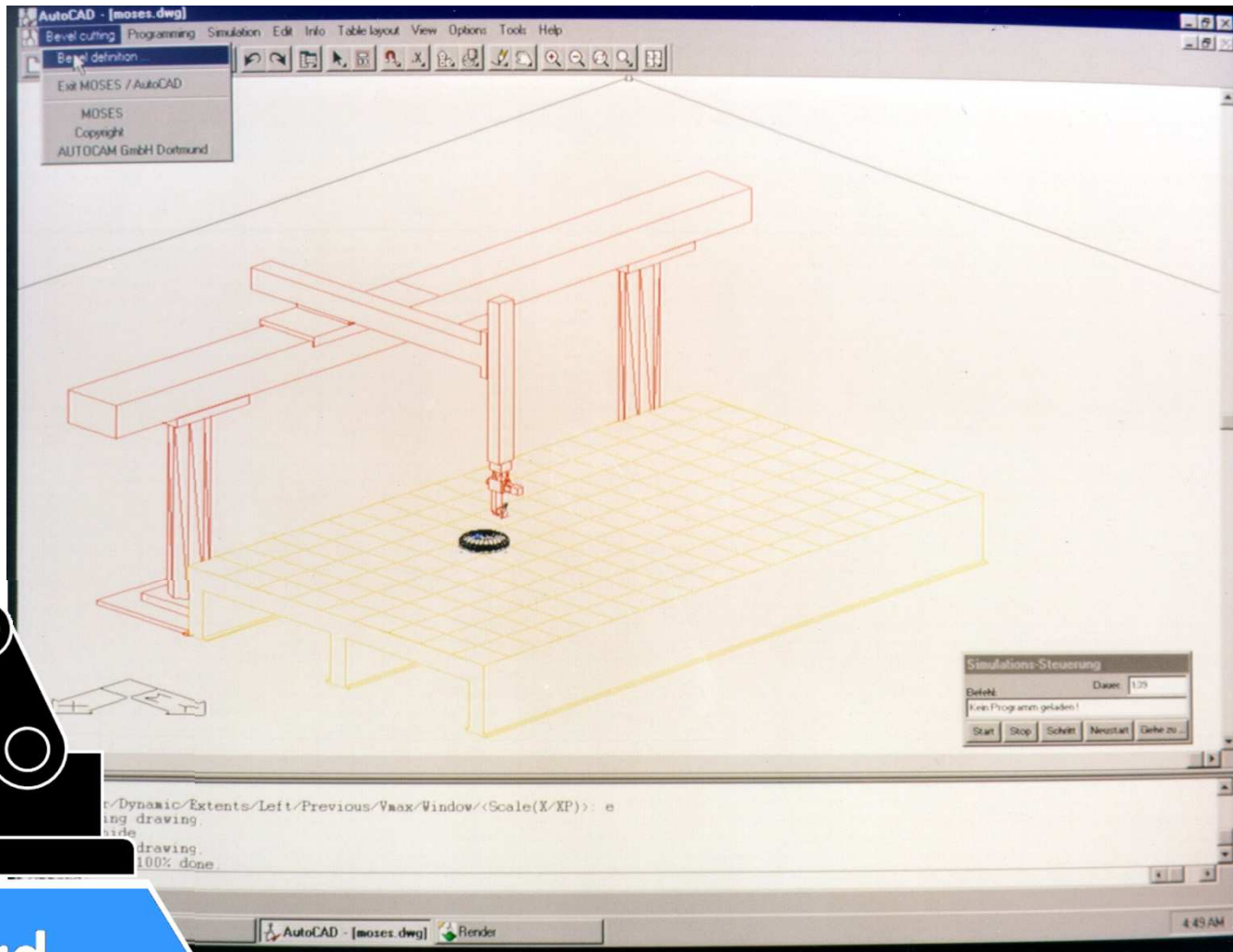

Offline Robot programmeren

Exner

Robotprogrammeren in een virtuele omgeving, al 20 jaar



3rd

Offline Robot programmeren

Exner

Robotprogrammeren voor enkel stuks, klein serie productie

Online Robot programmeren



Offline Robot programmeren

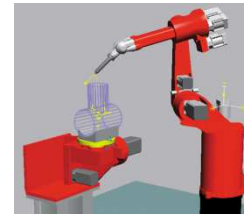

Instant Robot programmeren

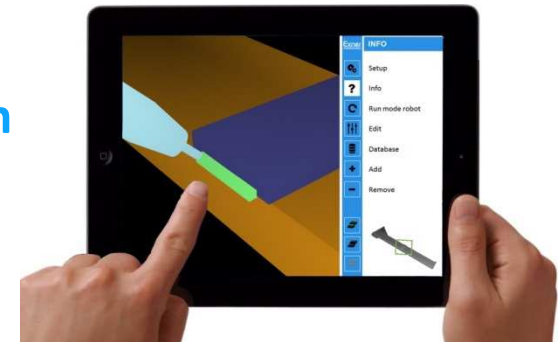

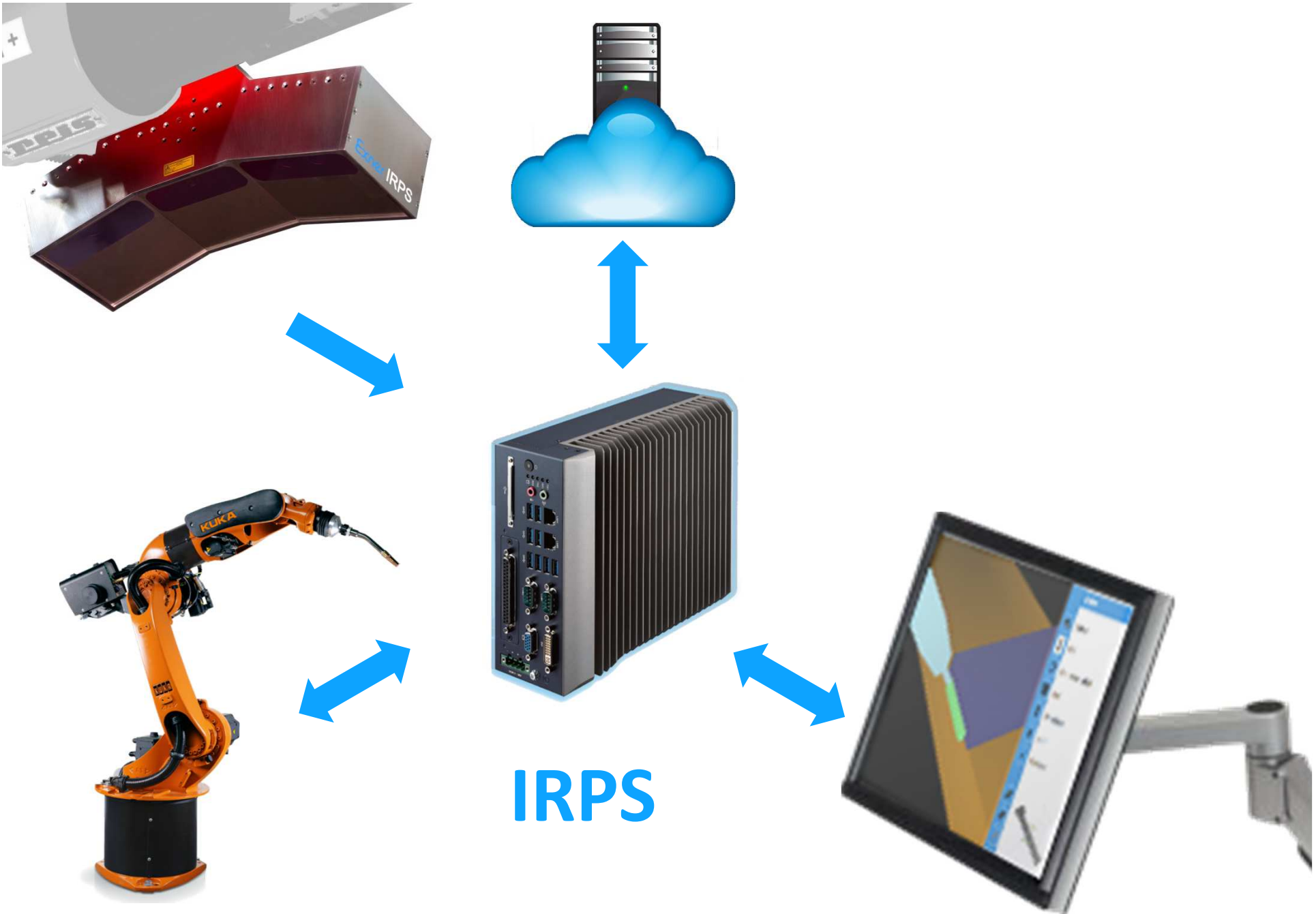

Exner Instant Robot Programming System

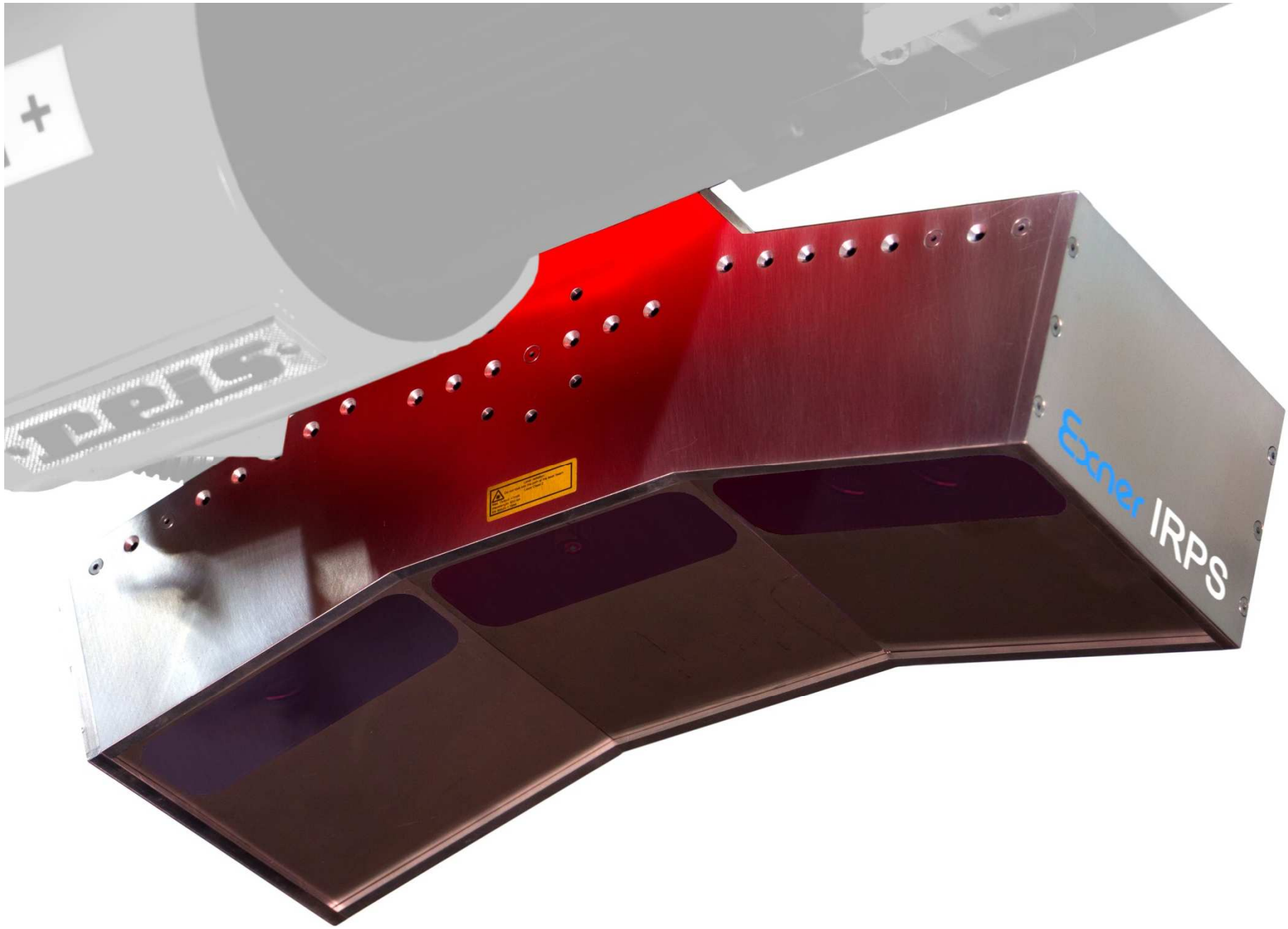

Exner Instant Robot Programming System

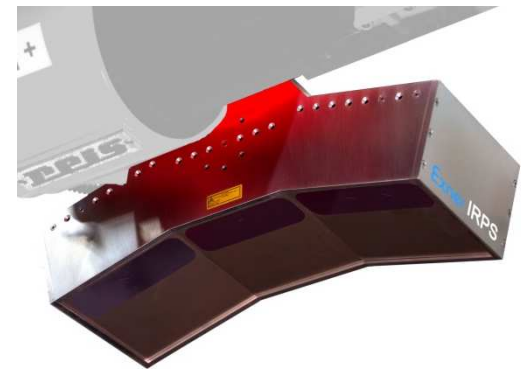
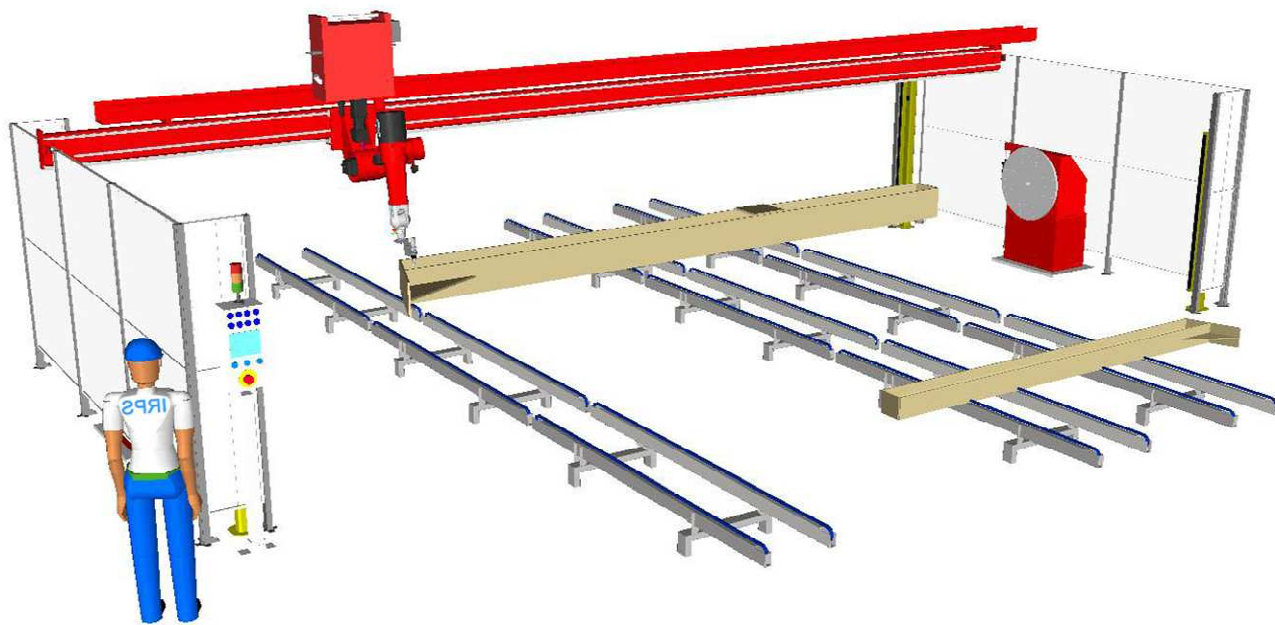
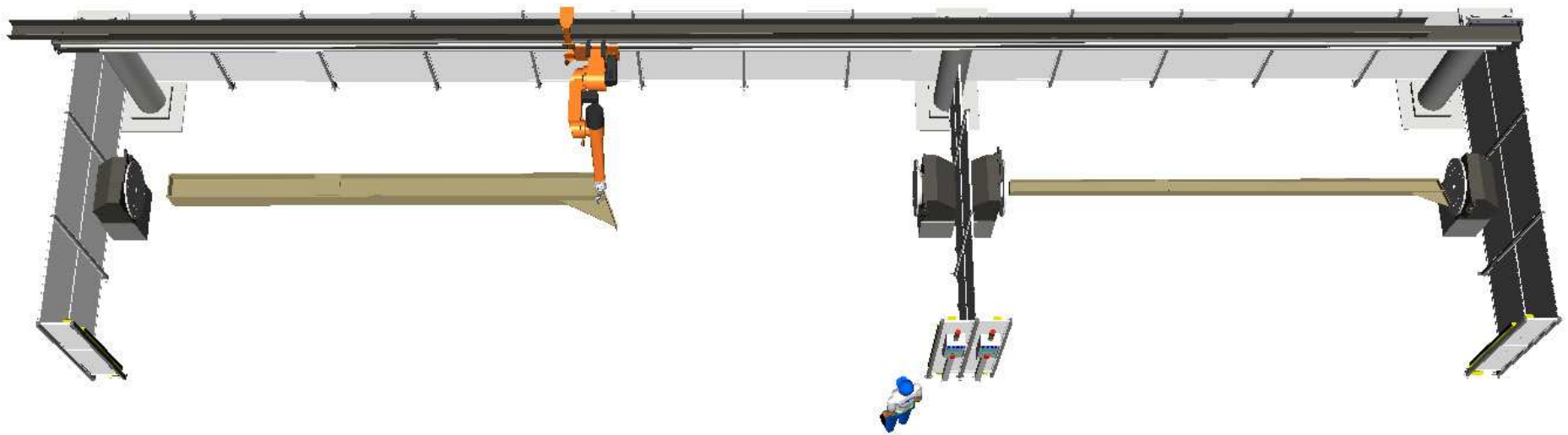

Exner

Voorbeelden lay-out robot cel voor lassen profielen

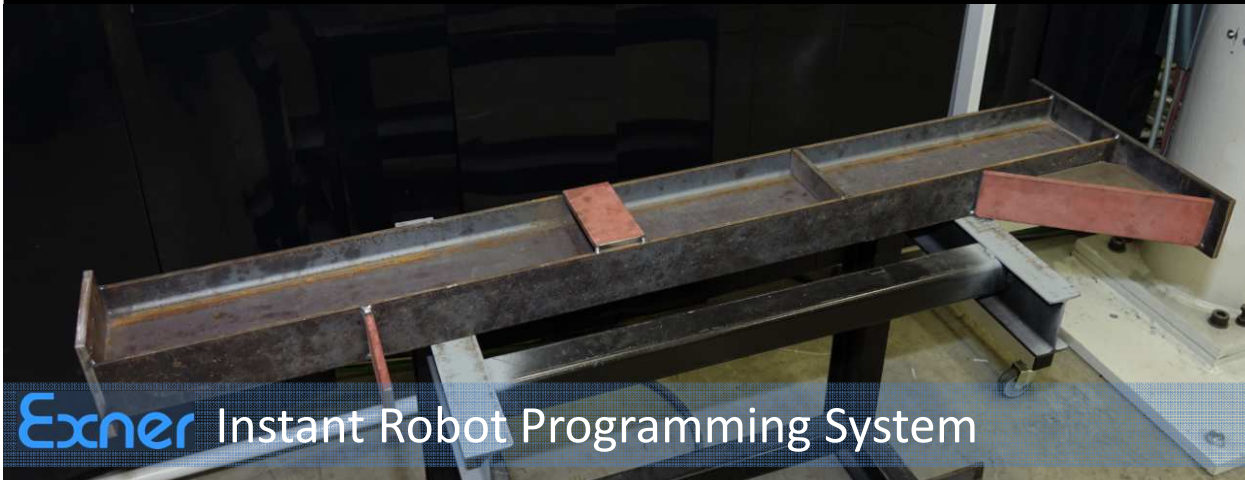
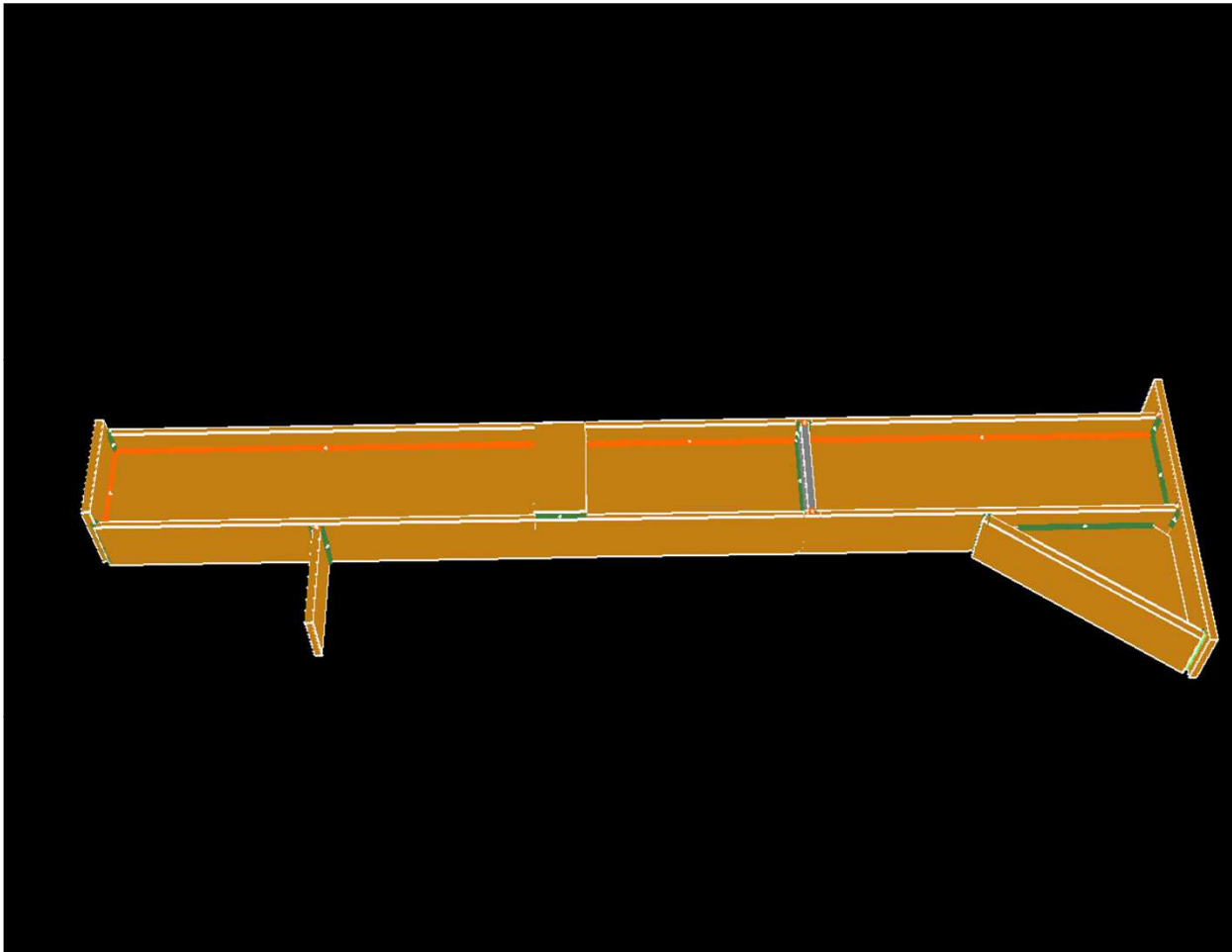

Home | | |

Cyclus ..

Info

Name

Comprised of: 382 shapes
132 faces
872 corners
44 potential welds

| | | | | | | |

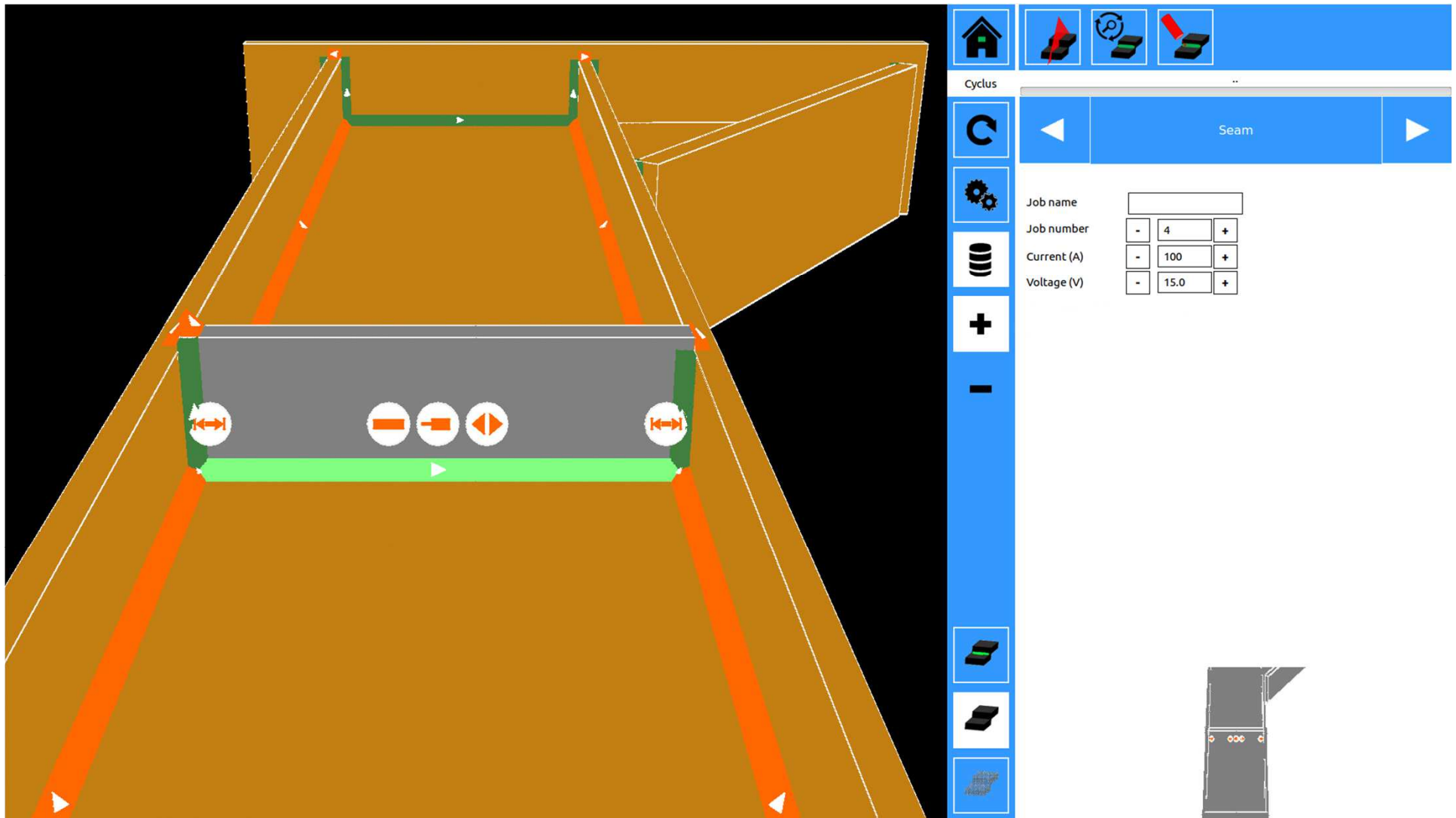

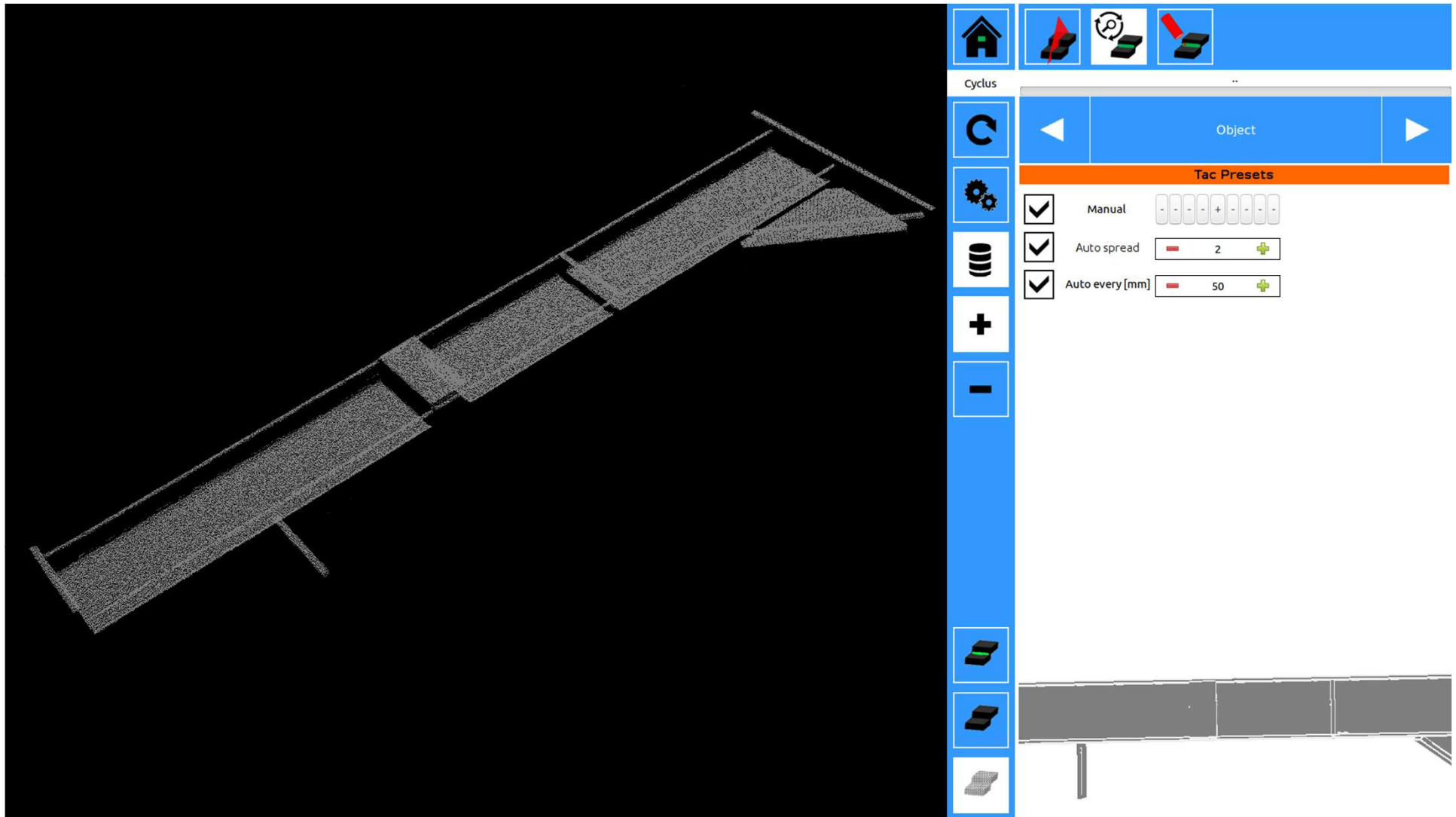

Exner De 3D-scanner kijkt van boven dus ondergelegen objecten zijn niet zichtbaar

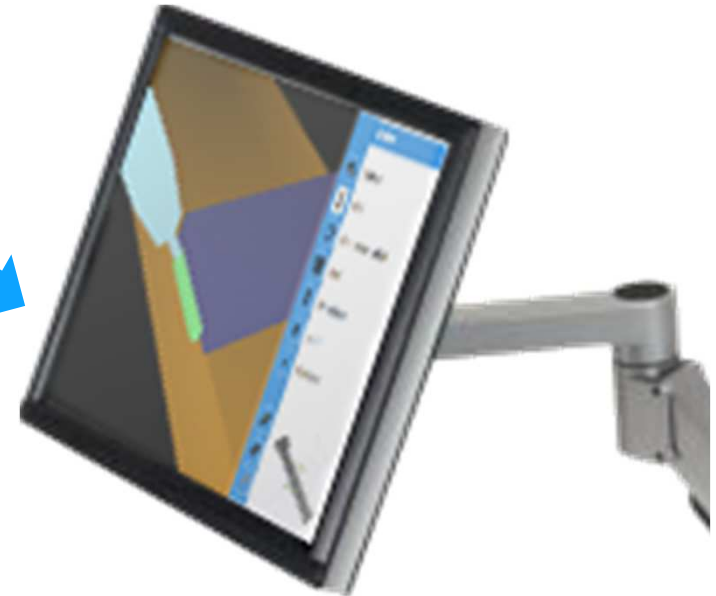
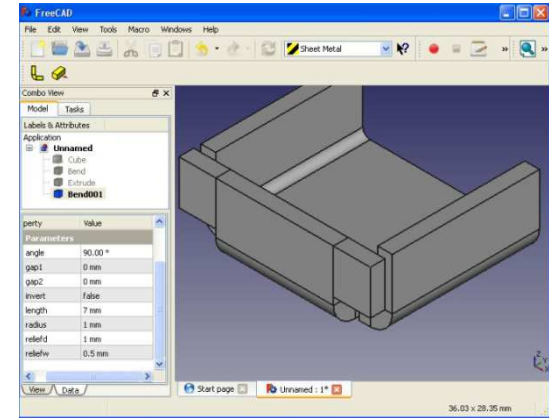
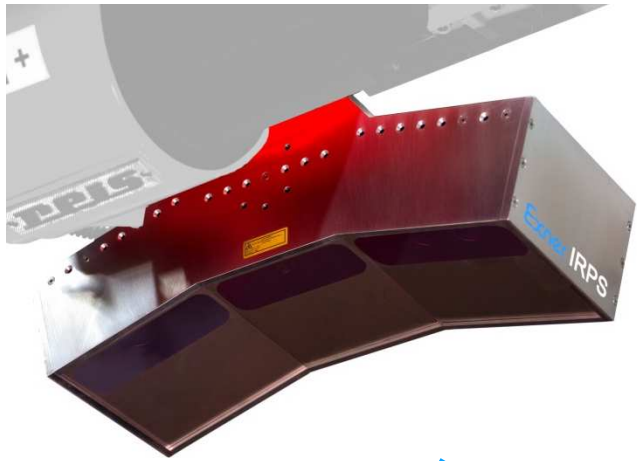

IRPS

Exner Instant Robot Programming System: CAD files importieren

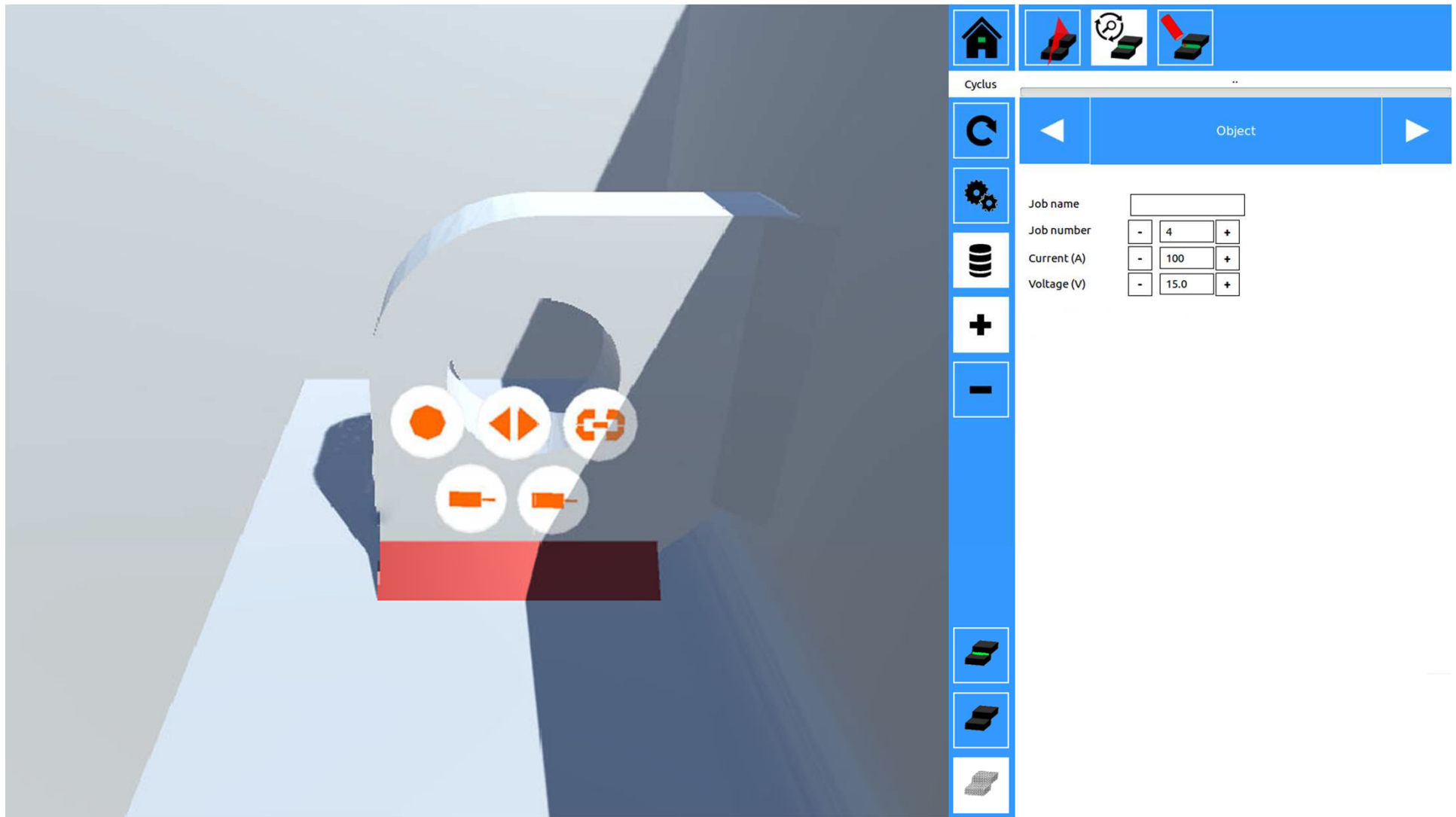

Robot programmeren

Online Offline Instant

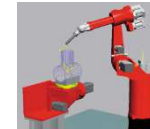

Programmeren tijdrovend

Ja

Deels

Nee

Robot draait door tijdens programmering

Nee

Ja

n.v.t.

Programmering op het werkelijke product

Ja

Nee

Ja

Zoeken product vereist

Nee

Ja

Ja, scantijd

Kennis van computers vereist

Nee

Ja

Nee

Kennis robot programmeren vereist

Ja

Ja

Nee

Kennis lassen vereist

Ja

Ja

Nee

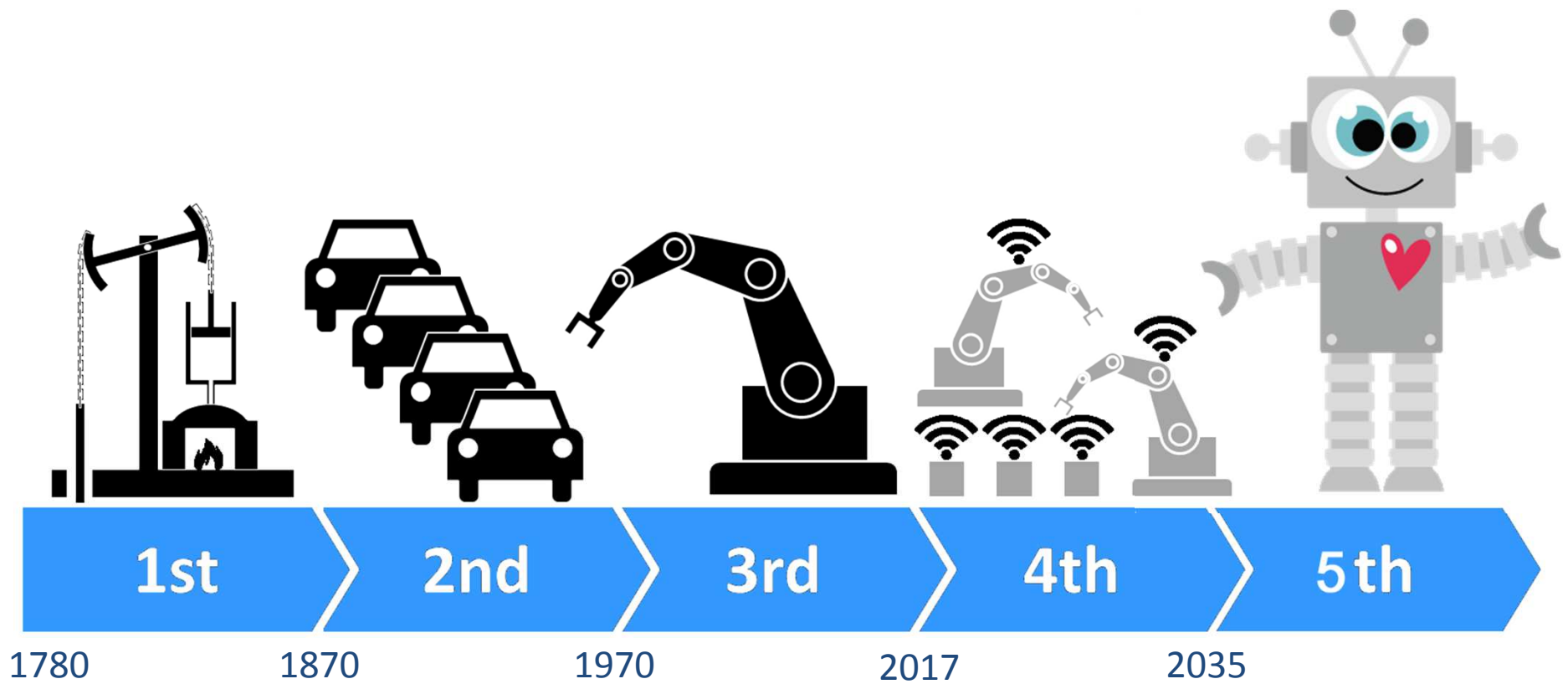

**hartelijk dank
voor uw interesse**

